

EQUIPMENT MANUAL

MAGNACHECK

1D & 3D TANGENTIAL FIELD STRENGTH METER



Contents

1	Introduction	2
1.1	General.....	2
1.2	Features.....	2
1.3	Safety precautions.....	2
2	Standard Package and Accessories	3
2.1	Standard Package.....	3
2.2	Recommended Accessories.....	3
3	Operation	4
3.1	Connecting the probe	4
3.1.1	Calibration label.....	4
3.2	Appearance	4
3.2.1	MagnaCheck 1D and 3D probes.....	4
3.2.2	MagnaCheck unit.....	5
3.2.3	Instrument controls.....	5
4	Menu screens	6
4.1	Reading Screen Layout.....	9
5	Specification	11
6	Principles of 3D magnetic field strength probe operation	11
7	Calibration	14
8	Warranty, maintenance and battery replacement	14
8.1	Warranty.....	14
8.2	Preventive Maintenance.....	15
8.3	Battery Replacement.....	15

1 Introduction

1.1 General

The MagnaCheck incorporates a unique system concept, whereby the instrument acts solely as a display and power source, while the interchangeable probes store calibration details.

Therefore, only the probes require calibration. This allows the user to interchange probes and for the one MagnaCheck instrument to remain in continuous use.

In addition to providing conventional 1D tangential field strength measurement, the MagnaCheck introduces the innovative concept of 3D field strength measurement to provide greater accuracy and ease of operation.

1.2 Features

- 1D and 3D probes.
- Improved measurement repeatability using 3D probe.
- Ruggedized probe design suitable for industrial NDT.
- DC, RMS and AC peak measurement
- Interchangeable probes allow the MagnaCheck to operate continuously.
- Detachable cable from both probe and instrument.
- Lightweight and compact.
- Long battery life.
- Ergonomically designed.
- Full colour LCD.

1.3 Safety precautions

Please be sure to read and adhere to all the guidelines set out in this user manual. The precautions are in place for your own safety, and to ensure optimum product performance.

When taking measurements of magnetic fields, care should be taken to limit personal exposure to electromagnetic radiation.

The MagnaCheck probes and instrument have been designed for use in an industrial NDT environment, however care should be taken to ensure that contact with magnetic ink and penetrants is kept to a minimum.

See Section 8, Warranty, Maintenance and Battery Replacement, for more information.

2 Standard Package and Accessories

2.1 Standard Package

The MagnaCheck is supplied with the following as standard:

Description	Part Number
MagnaCheck Instrument	IMAG001
3D or 1D probe	PMAG001/002
Magnetic field null pot	A241
Blue rubber boot for instrument	CHH453BBL
2x AA alkaline batteries	N/A
Carry case	N/A
Quick reference guide	N/A
MagnaCheck instruction manual	



2.2 Recommended Accessories

Additional probes:

Since calibration data is stored in the probe itself, it is possible to interchange calibrated probes with the instrument for continuous operation. Additional probes may be purchased for this purpose, and may be 3D or 1D type.

Additional probe cable:

In the event that the universal probe cable suffers damage in use, Baugh and Weedon recommend that a spare is available to minimize down-time.

Spare Batteries:

Spare 1.5 V AA batteries are recommended in order to minimize down-time.

3 Operation

3.1 Connecting the probe

The MagnaCheck instrument, cable and probes are supplied as separate items. These need to be connected in order to use the product.

1. Line up the red dots on the cable plug and the probe socket with each other and push the two together.
2. Now connect the cable to the instrument in the same way.

3.1.1 Calibration label

Each probe will be provided with a label detailing the following information.

- Probe serial number.
- Date of calibration.
- Due date of next calibration.
- Calibration certificate number.
- Name of calibration technician.

Ensure that the calibration status of the probe meets your quality procedures.

3.2 Appearance

3.2.1 MagnaCheck 1D and 3D probes



Figure 1 - 3D Magnetic field strength probe (left), 1D Magnetic field strength probe (right).

3.2.2 MagnaCheck unit



Figure 2 - MagnaCheck Instrument.

3.2.3 Instrument controls

General descriptions of instrument controls are provided below, specific operation depending on instrument function are detailed in Section 4.



Power button – single press to turn on. Press for 2 seconds and release to turn off.



Back button – return to the previous display. From the main screen, switches to measurement display.



OK button – to select menu items and change parameter values. From the main screen, switches to the parameter menu.



Up arrow – moves up through menu options.



Down arrow – moves down through menu options.



Left arrow - moves between screens.



Right arrow – moves between screens.

4 Menu screens

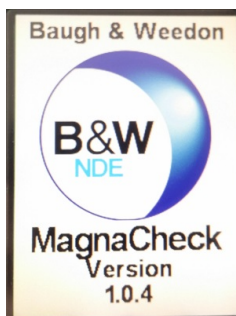

Splash Screen

Press the Power button to turn on the instrument and the Splash Screen will appear during power-on. The Home screen will then be displayed.

Details of the software version are included in the Splash Screen.

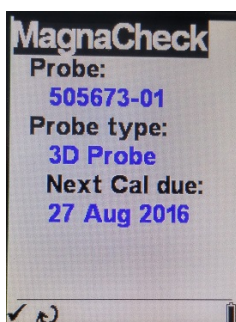

Home Screen

Probe: Check the serial number shown matches the number on the probe label.

Probe type: Confirms that a light meter probe is attached.

Next Cal due: Displays the calibration due date.

Operation: Back button – Go to measurement display.
Down arrow/OK button – Go to Top Level menu screen.

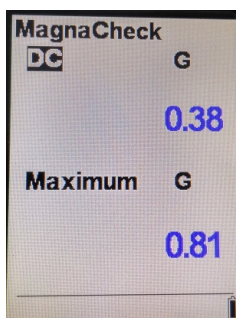

Measurement displays

The measurement display is split into two halves, the top displays the live field strength measurement and the bottom displays the maximum reading for the hold time specified.

Operation: Back button – switch between measurement and home screens.
OK button – Zero the Field Strength measurement, with the probe in the null pot provided.
Up & Down arrows – Selects between upper and lower sections of display.
Left & right arrows keys – Cycles through measurement modes, and activates Maximum display reading.

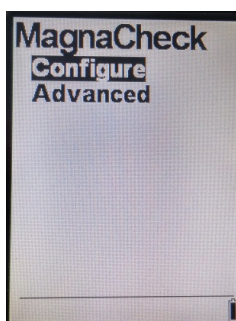

Top Level Menu

This menu has a number of sub-menus where instrument parameters can be configured.

Operation: Up & down arrows – Moves between menu items.
OK button – Use to select a menu item.
Back or left arrow button – Return to Home screen.



Configure Menu

This screen shows the sub menus for the Configure menu.

Operation: Up & down arrows – Moves between menu items.
OK button – Use to select a menu item.
Back or left arrow button – Return to Top Level menu.

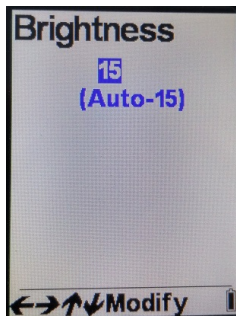

Brightness

Change the brightness of the MagnaCheck screen.

Operation: All Arrows – Left or Down to reduce brightness.
Right or Up to increase brightness.
OK button – Use to set the selected level.
Back button – Return to Configure menu.

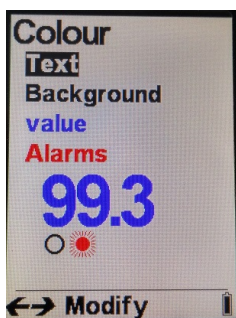

Colour

Configure the colour of text, background, value and alarms to suit your preferences.

Operation: Up & down arrows – Moves between parameters.
Left & Right arrows – Cycles through the colour options for each parameter.
OK button – Use to set the selected colour.
Back button – Return to Configure menu.

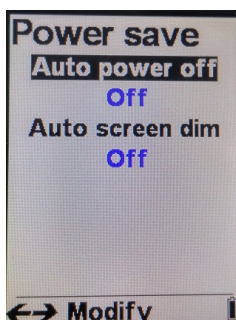

Power save

Set the Auto Power Off and Auto Screen Dim timings when the MagnaCheck is idle.

Operation: Up & down arrows – Moves between parameters.
Left & right arrows – Select the required time delay.
OK button – Use to set the selected time delay.
Back button – Return to Configure menu.

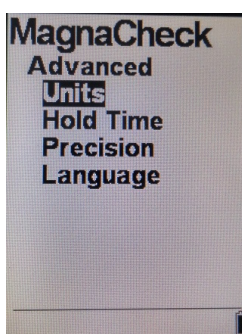

Advanced menu

This screen displays the sub menus for the Advanced menu.

Operation: Up & down arrows – Moves between menu items.
OK button – Use to select a menu item.
Back or left arrow – Return to Top Level menu.

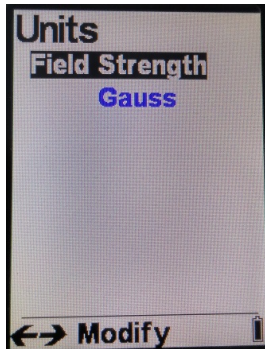

Units

Select the measurement units for magnetic field strength readings.

Operation: Left & right arrows – Selects G, mT, or kA/m.
OK button – Use to confirm unit selection.
Back button – Returns to Advanced menu.

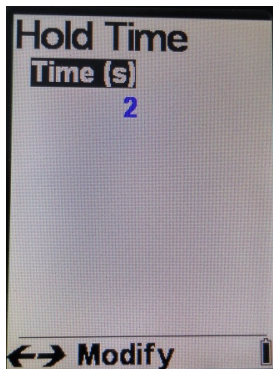

Hold Time Menu Screen

Sets the length of time over which maximum readings are calculated.

Operation: Left & Right arrows – Selects the hold time (1,2,5 or 10 seconds).
OK button – Use to confirm selection.
Back button – Returns to Advanced menu.

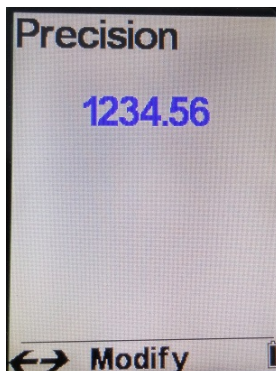

Precision

Sets the resolution of magnetic field strength readings.

Operation: Left & right arrows – Switches between two precision options.
OK button – Use to confirm precision selection.
Back button – Returns to Advanced menu.

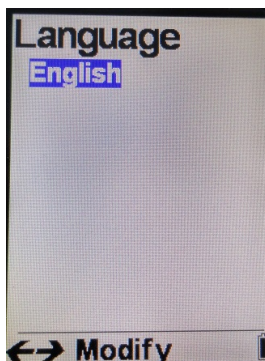

Language

Selects the displayed language. Supported languages are:

- English
- French
- Spanish

Operation: Left & right arrows – Select the language to display.
OK button – Use to confirm language selection.
Back button – Returns to Advanced menu.

4.1 Reading Screen Layout

Free field mode with 3D Magnetic Field probe connected

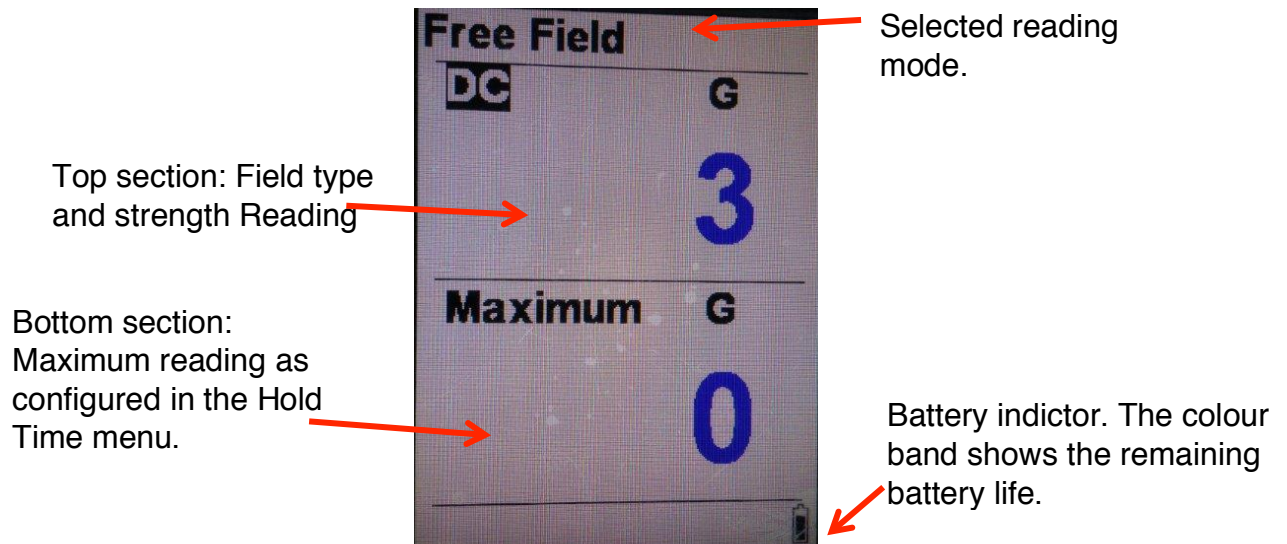

Figure 3 - Measurement display layout in free field magnetic measurement mode.

Face select mode with 3D Magnetic Field probe connected

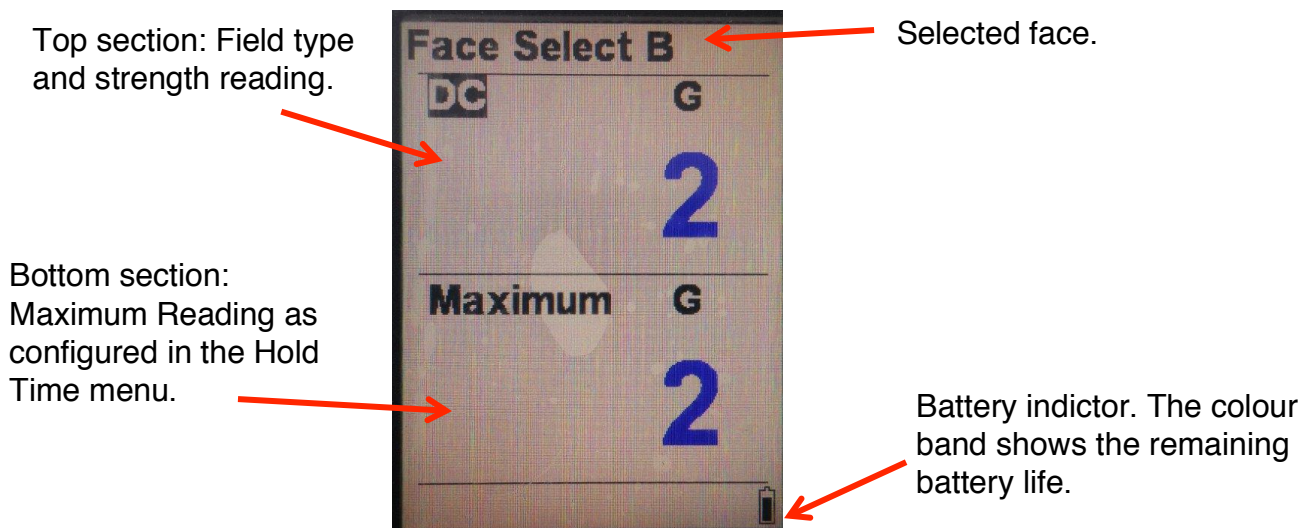

Figure 4 - Measurement display layout in face select magnetic measurement mode.

Timer mode with 1D Magnetic Field probe connected

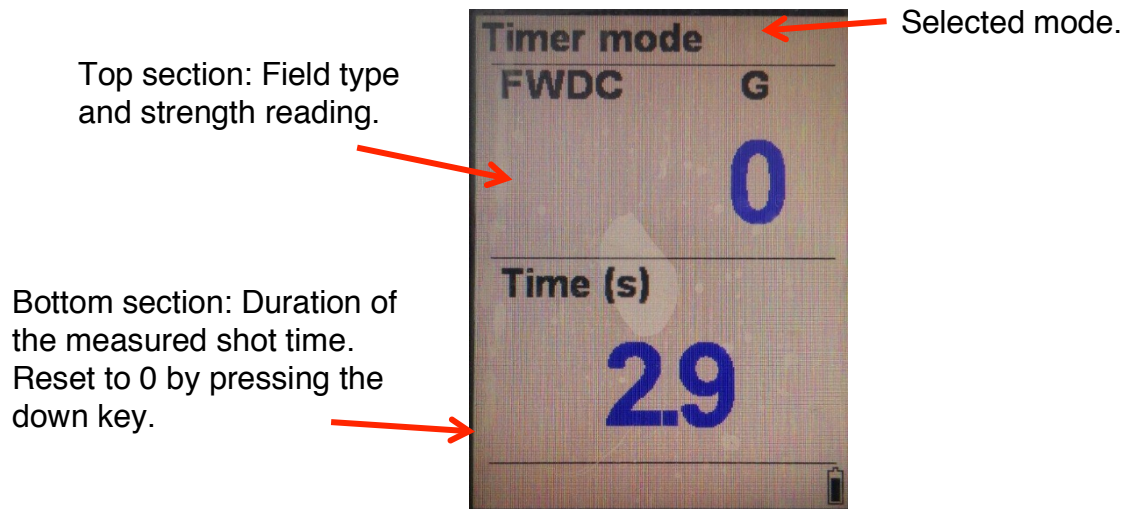

Figure 5 - Display layout in shot timer mode.

5 Specification

	MagnaCheck 3D	MagnaCheck 1D
Measurement range	G: 0 to 2,000 kA/m: 0 to 159 mT: 0 to 200	G: 0 to $\pm 1,000$ kA/m: 0 to ± 79 mT: 0 to 200
Resolution	G: 0.01 kA/m: 0.01 mT: 0.01	G: 0.08 kA/m: 0.01 mT: 0.01
Units	Gauss, milliTesla, kiloAmps/metre	
Measurement modes	DC, AC peak, true RMS	DC, AC peak, true RMS
MPI bench features	True RMS for thyristor switched fields	True RMS and shot time measurement
Reading maximum hold times	Off, 1, 2, 5 and 10 seconds	
Measurement sample rate	70 measurements/sec	500 measurements/sec
Sensor calibration	Stored digitally in probe	
Measurement accuracy	$\pm 5\%$	$\pm 5\%$
Applicable Standards	ASTM E1444/1444M-16 and EN ISO 9934-3 2005	
Zeroing	Manual zero with null pot supplied	
Display type	2.8" (70mm) 320 x 240 pixels colour backlit LCD	
Power	2 x 1.5V AA batteries, 6 hours continuous operation	
Instrument dimensions	168mm L x 85mm W x 30mm D	
Instrument weight	350g (0.77 lb) including batteries	
Environmental:	Altitude up to: 2,000m Temperature: 0°C to 40°C Maximum relative humidity: 5% to 95% non-condensing IP Rating: Designed to meet IP54	

6 Principles of 3D magnetic field strength probe operation

Traditional magnetic field strength measurements are performed with a single Hall Effect sensor, which provides an output voltage proportional to the instantaneous magnetic field strength perpendicular to the sensor.

This results in considerable measurement variation dependent on the respective orientations of the sensor and the magnetic field. Careful, precise positioning and orientation of the sensor is required to ensure that the maximum field strength is accurately measured. This introduces practical difficulties for the operator, and the potential for significant measurement error.

The 3D magnetic field strength probe incorporates 3 orthogonally arranged Hall Effect sensors in a rugged probe housing, which simultaneously measure the instantaneous magnetic field strength in 3 axes as shown in Figure 6.

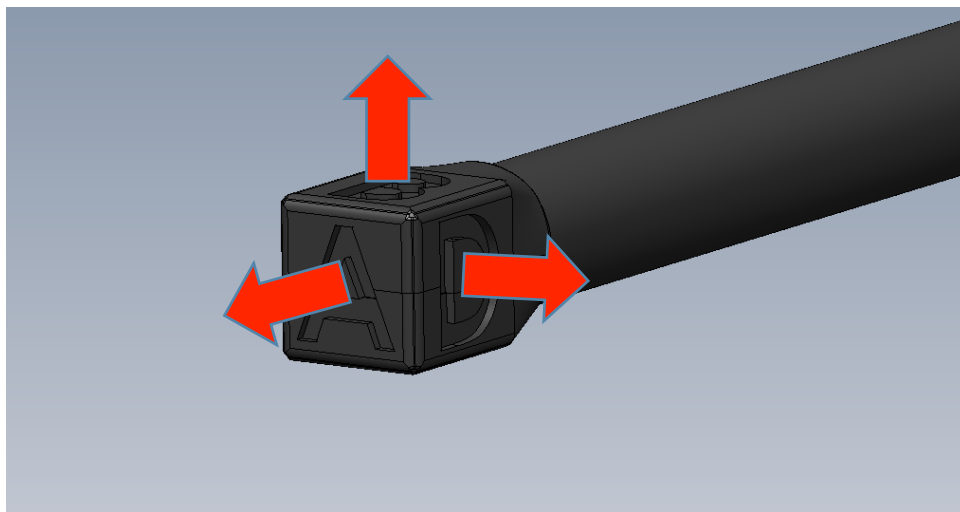

Figure 6 - 3D Magnetic field strength probe, illustrating orthogonal measurement axes.

This allows for the maximum field strength to be determined irrespective of the relative alignment of the magnetic field with the probe by calculating the magnitude of the field from each vector. Figure 7 illustrates a measurement being taken, with annotation showing acceptable variation of probe orientation with respect to the field.

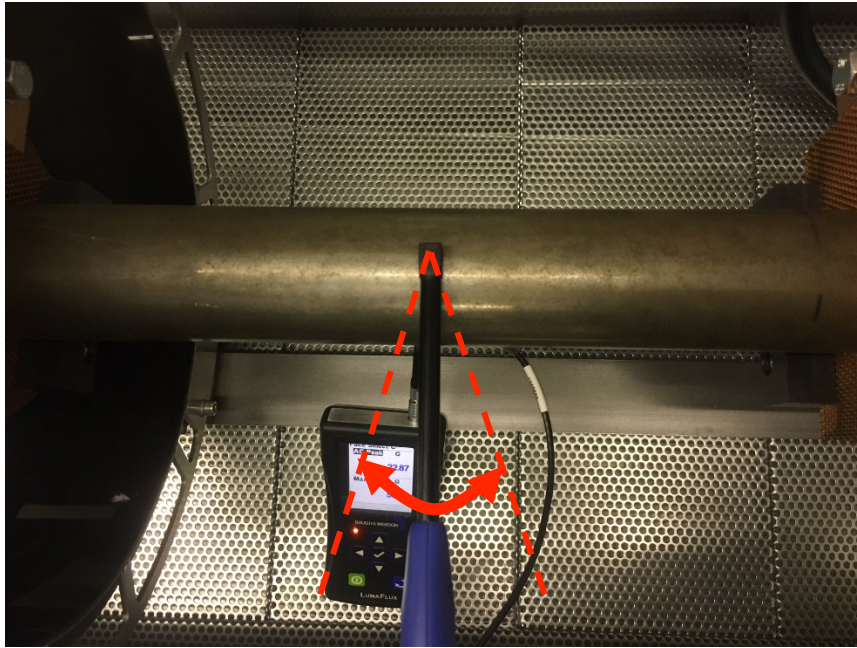

Figure 7 - 3D Magnetic field strength probe orientation.

The implementation of the 3D magnetic field strength probe in the MagnaCheck product allows for two methods of operation.

Free Field Mode

Free field mode uses the magnitude of the field strength from all three sensors, to calculate a single magnitude value, and is sensitive to the magnetic field in all vectors. It does not discriminate between wanted and unwanted components of the magnetic field.

When taking measurements of magnetic field strength at the surface of a part in a MPI bench, free field mode may not be appropriate, because the unwanted component of the field, perpendicular to the part will also be measured. This will result in an over-reading of the field strength in comparison with a 1D magnetic field strength probe placed at the part surface aligned with the field of interest. In this instance, Face Select mode should be used. Typical applications for Free Field Mode are:

- Measuring the magnitude of the field strength in Helmholtz coils.
- Measuring the magnitude of the field strength in a de-magnetisation coil.

Face Select Mode

Face select mode allows the operator to place one of 5 designated probe faces onto the part surface, and the unwanted perpendicular element of the magnetic field is rejected from the magnetic field strength calculation as illustrated in Figure 8. The remaining 2 sensors are used in the magnitude calculation, permitting compensation for inaccurate probe orientation, resulting in better measurement repeatability compared with using a conventional 1D probe as shown in Figure 8.

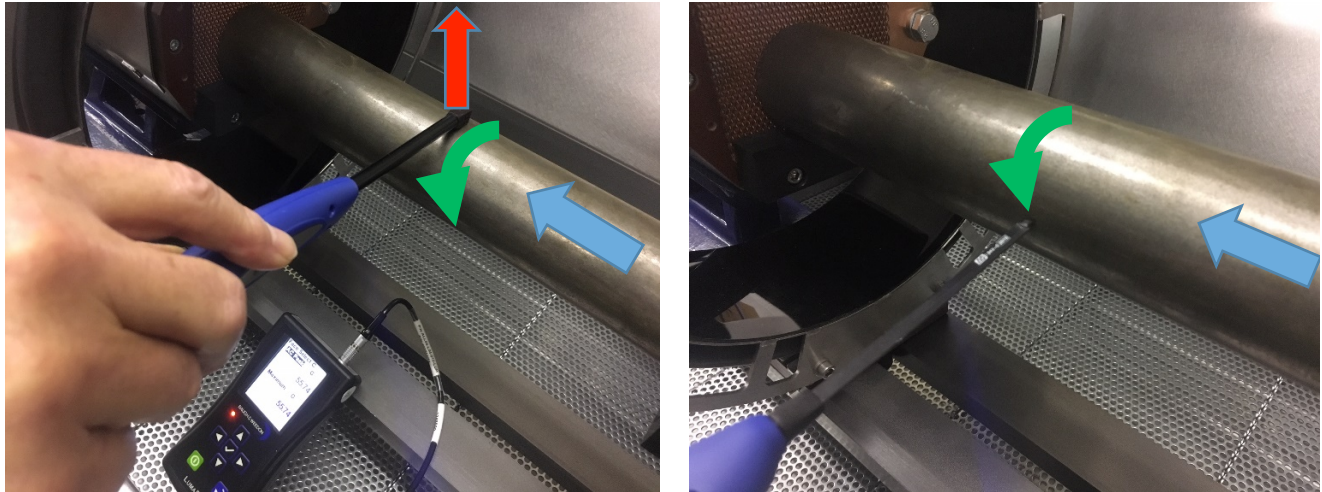

Figure 8 - Illustration of field strength measurement using an MPI bench. 3D measurement (left), 1D measurement (right). Direction of current (blue), field of interest (green), unwanted field (red).

7 Calibration

A certificate of calibration is supplied with the MagnaCheck probes detailing the calibration equipment used, its calibration traceability, test conditions, measurement results, acceptance criteria and a certificate number.

The MagnaCheck Home Screen provides the due date of the next calibration in accordance with customer requirements. It is recommended that the MagnaCheck be recalibrated at least every twelve months.

For calibration of MagnaCheck please contact Baugh & Weedon or your local distributor.

8 Warranty, maintenance and battery replacement

8.1 Warranty

The MagnaCheck is provided with a one year warranty subject to fair wear and tear commencing from the date of dispatch, excluding batteries. Baugh & Weedon (the Company) undertakes to make good by providing a replacement or at its option repairing defects arising from faulty design, material or workmanship.

Defective goods must be promptly returned at the Purchaser's expense to the Company's factory in Hereford, UK. The goods must be accompanied by the purchaser's written order describing the defect and authorising the Company to invoice the Purchaser for any charges not covered by the warranty.

Please refer to Baugh & Weedon Ltd. standard terms and conditions of sale.

8.2 Preventive maintenance

- Ensure that the product is maintained in a clean condition.
- Do not use solvents on any part of the product.
- Do not immerse in water, wipe surfaces with damp cloth.
- Mild detergent may be used for cleaning, dry thoroughly before use.
- It is recommended that the instrument boot is removed and cleaned separately.

8.3 Battery replacement

1. Switch off the MagnaCheck instrument.
2. Disconnect the probe from the instrument.
3. Remove the rubber boot from the instrument.
4. Slide the battery cover down to expose the internal battery compartment.
5. Remove the used batteries and replace with new 2 x 1.5 V AA batteries.
6. Note the indications for battery polarity marked in the battery compartment.
7. Slide the battery cover back to the fully closed position.
8. Replace the rubber boot onto the instrument and reconnect the probe.